



1108 Lavaca St STE110
Austin Tx, 78701
512 377 6052

<http://awg18.com>

AL-DA-HAT (v2b)

Raspberry Pi to DALI Co-Processor

DALI power supply 16 volts
Raspberry Power 5 volts

See <https://atxled.com/pdf/AL-DALI-HAT-v1.pdf> for version 1 hardware,
see <https://atxled.com/pdf/AL-DALI-HAT-l.pdf> for 2 and 4 channels

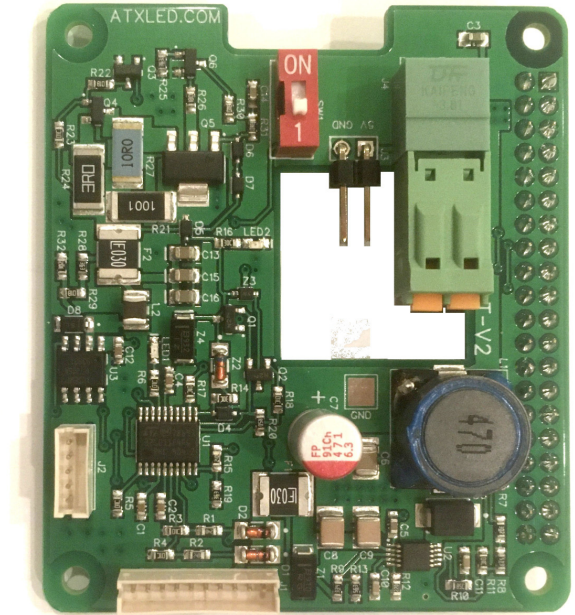

Product Description - AL-DA-HAT

This device interconnects a Raspberry Pi with a DALI bus. Using your own software or our ZWD application (available separately) – you can now control up to 64 addressable light fixtures from a Raspberry Pi.

Included in the AL-DALI-HAT are the following key functions

- DALI hardware interface
- DALI power supply (16v with 0, 80 or 220 mA) current limited
- 5V power supply for the Pi with 10 watts
- 5V power for a fan (2.54mm header)
- Real Time co-processor to offload the DALI bus hardware interface
- 44 to 56 volt input range, redundant inputs
- Serial port to the Raspberry Pi
- Dual Power supply monitoring for redundant voltage input
- DALI bus current and voltage monitoring
- Automatic DALI bus power level determination.
- User programmable switch
- Advanced self testing and testing of all DALI devices

Overview

We have designed this HAT to use the Raspberry Pi on-board serial port to communicate at 19200 baud to the DALI HAT, this rate is 16 times faster than the DALI bus – the hardware on the HAT adapts the UART serial data stream into DALI encoding. The Pi can read and write the DALI bus at it's leisure, the co-processor on the HAT handles all real-time functions. FiFo's on the HAT buffer the data.

Ordering part numbers

Model	DA Devices	Mounting	# DA Bus Power	ZWD Included
AL-DA-Hat	64	Free	1	No
AL-DA-Hat-2I	128	Free	0	No
AL-DA-Hat-4I	256	Free	0	No
ATX LED Hub	64	SML	1	Yes
ATX LED Hub 4I	256	DIN Rail	0	Yes
AL-DIN-DA2x+5v-m or AL-DIN-DA2x+5v-c	128	DIN Rail	2	No
ATX LED Hub 2I – kit with 1x DIN2	128	DIN Rail	2	Yes
ATX LED Hub 4I - kit with 2x DIN2	256	DIN Rail	4	Yes

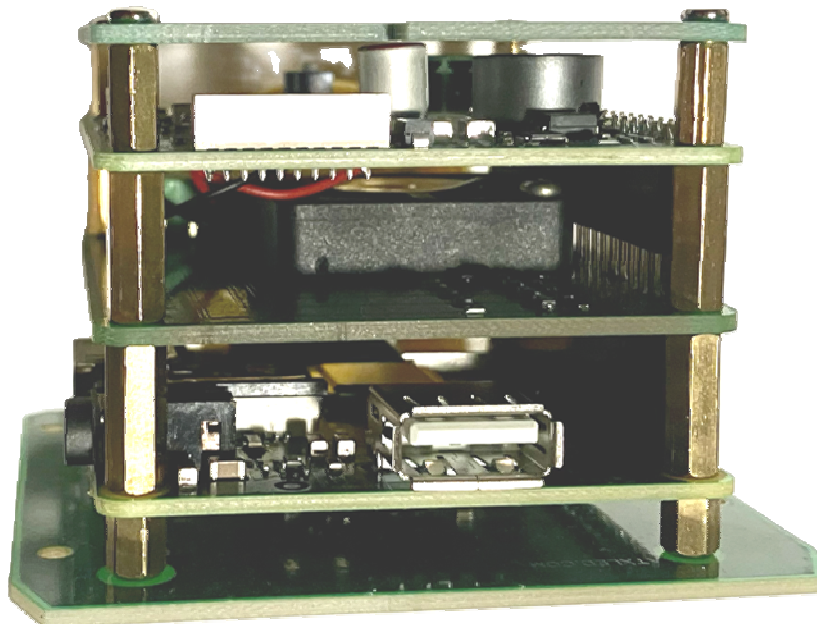

ATX Hub with RPI A+

Leviton 47605 installation – 64 devices

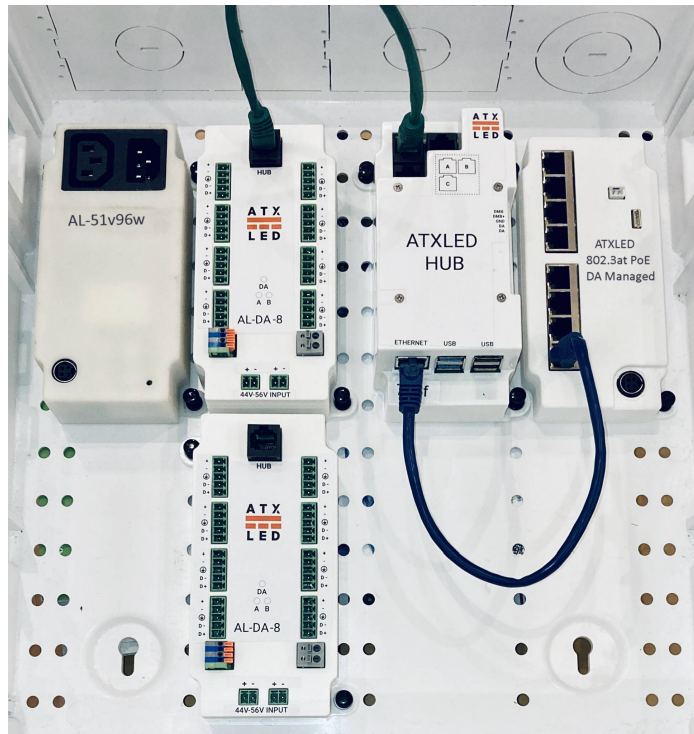

DIN-Rail installation – 64, 128, 256 devices



Wiring Connections

Raspberry Pi power source

The 10 pin cable can provide the power input and ground – 40 to 56 volts is required. The HAT delivers 5 volts 10 watts to the PI from the 48v input.

If you use the Micro USB connectors on the Pi module to provide power to the Pi, then you don't need the 48v, the Pi will power the Hat – everything will work. However there will be no DALI bus power.

Power for the DALI bus

In addition to powering the Pi itself, the Hat can generate the DALI bus current. Two inputs allow redundant supplies to be used – pins 3 and 4 are not connected together.

Fan power

A 2 pin, 2.54mm header provides +5 volts for a fan. Do not jumper or short!

Power Monitoring and Failover

The 2 power inputs on the 10 pin connector are designed to detect redundancy – the board will operate with either connected, and will signal to the Pi if one of the two inputs has no power.

DALI bus connection

There are two DALI connection methods. The Green 2 pin plug or the white 10 pin connector cable provided. The 10 pin cable has DALI – minus on pin 1 and DALI + plus on pin 8. Note – because there is an on-board power supply, the polarity is significant, and the power ground and DALI ground are connected.

Passive PoE Option

An RJ-45 type jumper cable is available. This connects the 10 pin white connector to an RJ45 cable, this cable is then compatible with other ATX LED products like the AL-PSE-4D, AL-PSE-8D, AL-PSE-24D and AL-PWS-8

DALI bus current control

You can use an external DALI power supply, or the internal one, or both. DALI allows parallel power supplies. The DALI bus must have a total current limit (maximum 260 mA and 16 volt) for normal operation. Higher currents limit the DALI bus length, so less is better. Budget 4 mA for each device on the DALI bus – so 80mA will power 20 devices. The HAT has an on-board DALI power supply that can be set for 0, 80 or 200 mA. From the factory – the device is set to automatically measure the available current on the bus and supplement as needed at power on. By default – the dip switch controls the maximum current – ON allows up to 260 mA, OFF allows up to 170 mA. The internal supply will be set automatically to meet the dip switch setting. With the Q command the automatic mode can be disabled. Lower DALI bus current allows longer DALI bus lengths over thinner wire.

Q value	Read back status from the Hat	Write to the Hat
0	Auto – Current Source off	Turn onboard DALI current off
1	Auto – Current Source @ 80 mA	Set DALI Current Source to 80 mA
3	Auto – Current Source @ 200 mA	Set DALI Current Source to 200 mA
4	Frozen – Current Source off	Enable Automatic detect, run now Unlock if frozen
5	Frozen – Current Source @ 80 mA	Freeze settings, retain the existing Off / 80 / 120 setting. Disable auto detect switch will be ignored at next boot
6	n/a	*Query status without changes or scan
7	Frozen – Current Source @ 240 mA	n/a

* this command only in fw 14 or later

Software Switch

The HAT has an onboard switch that can be used for any software defined function. At default it is used to select the bus current at power up. This bus current control can be disabled by software. Using the Q command – the switch function can be disconnected from the DALI power calculation and become useful for any software function.

Specifications

Name	Function	Description
Fan Power	Off board fan	Provides 5 volts for a fan – do not jumper short !!
Power	Internal Power consumption	100 milliwatt plus the Pi Peak power during DALI scan – 500 mW Each input voltage is measured and reported
DALI	DALI Bus (non isolated)	DALI bus on 10 pin ZHR connector pin 8 is DATA + voltage from onboard supply pin 1 or 2 can be used as DALI -
	Software controlled current	DALI bus on 3.81mm connector Kaifeng KF12EKN-2P Weidmueller BCF 3.81/02/180 196989000
Self Test	DALI Bus Quality	Measure DALI voltage at logic High and logic Low, real time Measure DALI current at 6 volts and 0 volts
Pi Power	Power to Pi	5 Volts to the Pi (pins 2 and 4) Ground (pins 6, 9, 14, 20, 25, 30, 34, 39)
Hat Power	Power from the PI	3.3 Volts from the Pi (20 mA) (pin 1) to the HAT
Serial IO	Interface to Pi	Serial Tx and Rx (pins 8, 10)
Programming	STM32	The onboard processor is programmed by a 5 pin ZHR connector
	Operating Temperature	0°C ~ 50°C
	Size	75 mm x 55 mm x 27 mm

Packaged Version – for Leviton 47605 panel

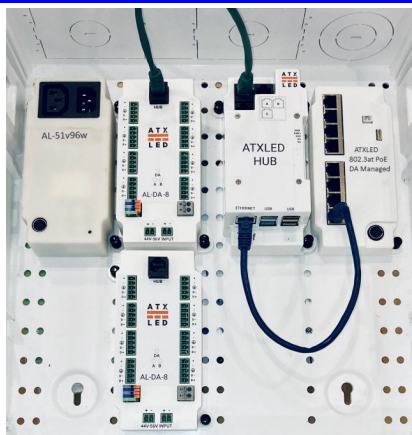

Wiring Connections – white 10 pin

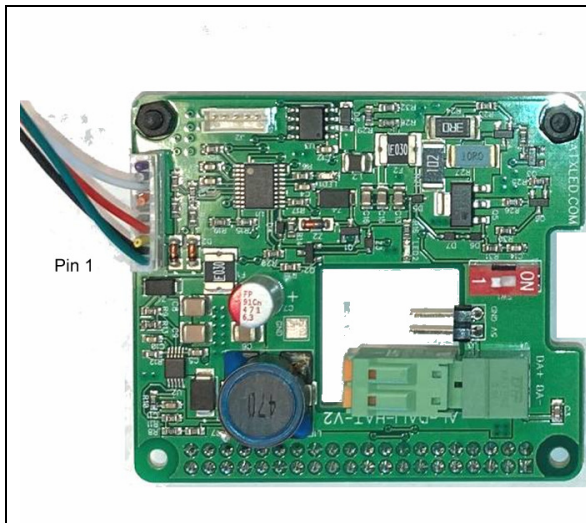

Pin	Function	Optional RJ45 cable
1	Ground	8
2	Ground	7
3	+ Voltage A	5
4	+ Voltage B	4
5	NC	6
6	NC	3
7	NC	2
8	DALI +	1
9	NC	-
10	NC	-

DALI bus length Limits

AWG wire	Distance @ 80 mA	Distance @ 260 mA
24	450 Ft	150 Ft
22	800 Ft	300 Ft
18	2400 Ft	800 Ft

Note: 2 pairs of cat-5e = awg 22 or better, 4 pairs = AWG 18

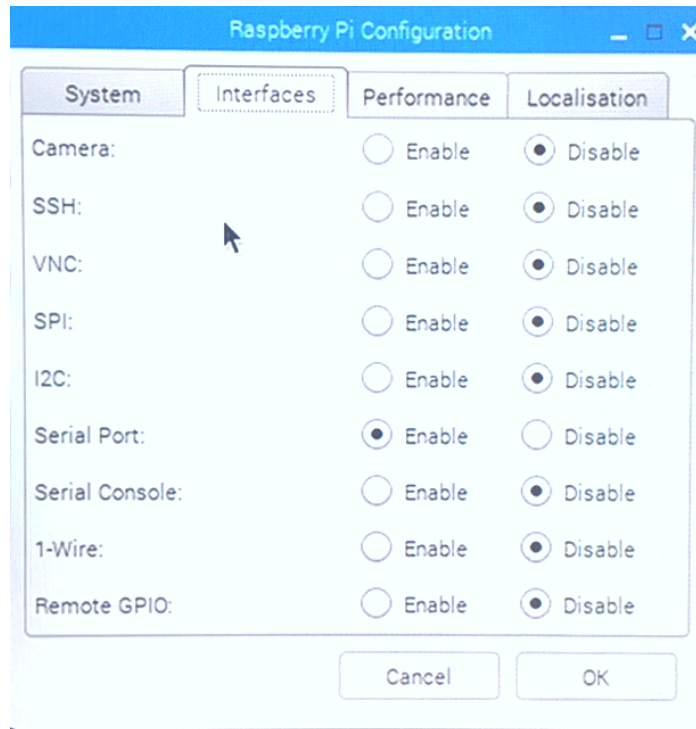

Packets from the Hat to the Pi (page 1)

At all times – the AL-DALI-HAT is listening to the DALI bus. Any commands on the bus will be forwarded to the Pi for recording the state of the DALI bus. Also status changes are sent.

The packets sent to the Pi start with a Capital Letter followed by values without commas:

- B means reboot, followed by 6 characters, HW version (2), SW version (2), channel count (2). This device has 1 channel
- D means DALI bus power supply status, 2 characters follow (one byte with status, then one byte = one channel => 1)
- H means receipt of a 16 bit DALI packet, 4 Hex characters follow
- J means receipt of an 8 bit DALI packet, 2 Hex characters follow
- L means receipt of a 24 bit DALI packet, 6 Hex characters follow
- N means no response received – normal in most cases (DALI NAK)
- M means receipt of a 25 bit DALI packet, 8 Hex characters follow (fw 18 or later)
- P is for power status, 2 voltage inputs plus the onboard switch status, 5 characters
- Q is for DALI bus quality – sent if major changes are detected. 16 characters
- S is the String stored in EEPROM (bytes 1-30)
- T is the String stored in EEPROM if longer than 30 bytes(bytes 31-59)
- U is the logic 0 voltage sensed during the last remote bus packet. Test quality of LED drivers
- V same values as B
- W calibrate voltages
- X means bus collision on Receive– normal in most cases
- Z means bus collision on Transmit– normal in most cases

The DALI power supply state is also sent proactively by the HAT if the DALI bus changes readiness

- D01 = no power on DALI , one channel
- D11 = Bus current too high – cannot drive to zero, one channel
- D21 = DALI bus OK, one channel
- D41 = Bus voltage > 24 volts, one channel

The DALI power supply quality response to the Q command is 16 characters and encoded as (Qmvvvvvxxxxyyyzzz)

- m = internal DALI power supply setting – see table above
- vvvvv = DALI Voltage – in millivolts (5 digits)
- xxx = DALI current in mA when bus is at 0 volts (3 digits)
- yyyy = DALI current in mA when bus is at 6.2 volts (initial – 4 digits)
- zzz = DALI current in mA when bus is at 6.2 volts (after 10 milliseconds – 3 digits)
- if the Bus falls below 12 volts – a packet will be set with yyyy and zzz == 999 indicating an error
- if the Bus Current changes by more than 60 mA – a packet will be set with yyyy and zzz == 888

The HAT version status info is encoded as (Vxxyzzz) (V is replaced by B when the HAT restarts)

- xx = Hardware Version
- yy = Firmware Version (decimal = 32 is 32 not 50)
- 01 = Hardware Type (see the wiki for Hardware types)

The HAT status info is encoded as (Pxxxyyyz) and is sent when a 500 mV change is detected.

- xxx = Power line A voltage (tenths of volts)
- yyy = Power line B voltage (tenths of volts)
- z = 0 or 1 for the Switch On/Off status

Packets from the Hat to the Pi (page 2)

A remote DALI devices ability to drive the DALI Bus current to a logic low value is captured and available as (Uxxxxxyyyy0000). Query a remote device so it sends a response, then send the U command to the Hat to report the logic zero level received.

- xxxxx = DALI bus logic 0 level in mV when the HAT drives the bus
- yyyy = DALI Bus logic 0 level in mV when a remote device drives the bus

Collisions on the DALI bus are expected during address search, but there are cases that are not expected. Check for lower than specified DALI bus voltages, higher currents than specified, or longer line lengths, the AL-DALI-Hat reports these errors.

- X4 = packet length error
- X3 = short bit received
- X2 = multiple packets received
- Z = Collision on transmit – normal, command should be resent

If there is no response to a packet after 100 ms – then a collision has occurred.

HAT to Pi	Structure	xx	yy	cc	zz
B Boot	Bxyycc	HW Version	FW Version	Switch	
H DALI 16 bit	Hxyy	DALI byte 0	DALI byte 1		
F Forwarding	See Forwarding				
J DALI 8 bit	Jxx	DALI byte			
L DALI 24 bit	Lxyycc	DALI byte 0	DALI byte 1	DALI byte 2	
M DALI 25 bit	Mxyycczz	DALI byte 0	DALI byte 1	DALI byte 2	DALI byte 3
N No Response	N				
P Power Status	Pxyyzz	0	0	Switch on/off	
Q Query	Q	N/A			
S Key Storage	S	See Key storage			
V Version	Vxyycc	HW Version	FW Version	Switch	
X Collision on Receive	Xx	Collision type			
Z Collision on Transmit	Zx	Collision type			
Other Collision	Null response				

[DALI Command Structure](#)

DALI commands for simple applications are 2 byte commands with either a 1 byte response or no response. The Wikipedia article offers a good explanation.

The 2 bytes of each basic command can be of these these types

- A) Simple Direct Light Level commands
- B) Complex commands for immediate action
- C) Complex commands requiring the command to be repeated once in 100 ms for action
- D) Complex commands using previously stored information

There are 3 types of addressing methods for these commands

- 1) Broadcast – all device receive the same information
- 2) Unicast – only one device receives the information
- 3) Group – only the devices in that group receive the information.

There are 64 individual addresses, 16 group addresses, one broadcast. The individual and group addresses are shift one bit left for transmission.

The AL-DALI-HAT accepts Hex commands to pass thru to the DALI bus. So Hex 2 is address one. The commands listed are in Decimal – please convert to hex. In Hex – the format is

Target	Direct Light Control	Complex Commands
Broadcast	FExx where xx is the light level	FFxx where xx is the command 0 thru 255
Individual	00 thru 7E (address times 2)	yyxx where yy is 01 thru 7F (addr x 2 + 1) xx is a command from 0 thru 255
Group	80 thru 9E (group times 2 + 128)	yyxx where yy is 81 thru 9F (group x 2 + 1) xx is a command from 0 thru 255
Broadcast		A1xx thru BFxx – commands 256 thru 271 xx is the data to the device
Broadcast		C1xx thru DFxx – commands 272 thru 287 xx is the data to the device

The DALI devices have up to 3 internal registers called DTR, DTR1 and DTR2.

Many complex commands require that the DTR register be written first, then the command is given. For example – setting the Maximum dimming level requires first a number be stored in DTR, then the DTR is stored into the device. AL-DALI-HAT accepts Hex commands to pass thru to the DALI bus. For example, setting device 5 to max level 240 (the range is 0 thru 254) the commands are

- a) A3F0 – save 240 into the DTR in all devices (broadcast)
- b) 0B2A – save DTR as max value only to device address 5 (times 2 plus 1 == B)

So Hex 0A is address five direct control and 0B is address five complex commands.

[DALI Bus Multibyte lockout](#)

Because some commands require more than one byte, if a load DTR1 (or DTR) command is observed on the bus, transmissions will be delayed by 120 (or 60) ms. This allows multiple masters to operate without interfering with memory and color commands.

Packets from the Pi to the HAT

The AL-DALI-HAT receives serial port strings from Pi and forwards them to the DALI bus. The packet is 2, 4, or 6 bytes long and begins with one of these characters. Length is the number of characters after the Command

:

Command	Length	Command type	Example
h	4	Send 16 bit DALI	hFE00\n all off
t	4	Send 16 bit DALI twice	t1120\n reset SA 8
j	2	Send 8 bit DALI	j80\n
l	6	Send 24 bit DALI	l101010\n
m	8	Send 25 bit DALI	M1101010\n
d	0	Query DALI bus info	d\n
p	0	Query Power info	p\n
v	0	Query Version	v\n
u	0	Query last DALI low	u\v
q	0	Query Quality	q\n
r	1	Set Power modes	r1\n
s	0	Query Text String	s\n
sxxxxxx	Up to 59	Save Text string – erase prior contents	Sabcdef\n
w	1	Query Calibration	W7\n
	5	Set Calibration +-xxxx mV	w8xxxx A side w9xxxx B side

r* available only on hardware with built in DMX ports

On receipt, the AL-DALI-HAT will wait for the DALI bus to be non busy, then will transmit the command. In the case of the t command – it will send the data twice within 100 ms.

Simple Serial I/O examples

See <https://atxled.com/Pi> for python code samples. Some DALI lighting control examples from Pi to Pi Hat to DALI bus are shown here

Function 00	Decimal command	Send to HAT	Response
All lights on full	254 254	hFEFE	None
All lights off	254 0	hFE00	None
Initialize	165 0	tA500	None
Query status of #4	9 144	h0990	6
Set #5 to 200	10 200	H0AC8	None

See <https://atxled.com/pdf/AL-WS-DR2.pdf> for a list of commands, see the wikipedia article on DALI lighting for the addressing format for DALI. Configure the Pi serial port as shown below

ATX LED ZWD Application

The ZWD package for the Raspberry Pi creates a complete DALI master with all features needed for configuration and management of a DALI system. It includes interfaces to Alexa, Google, Hue, Homebridge, Smarthings, Siri and so on.

The image displays several screenshots of the ATX LED ZWD application interface, organized into two rows. The top row shows the 'Admin' menu, a 'Status' page, a 'Query DALI Power Status' dialog, and a 'Manual level' control panel. The bottom row shows a 'DALI Devices' configuration screen for 'LDD' and a 'Schedule' management screen.

Admin Menu: DALI Devices, Other DALI, Groups, Scenes, Schedule, Triggers, DMX Groups, Hue, Admin (selected), Support, WiFi Setup, DALI Log, Advanced, ZWave, ZWave Logs.

Status Page: ZFDS version: 0285-4fd2aef, Channels: 1, HW type: AL-DALI-HAT v2 with DALI power, SW version: 02, FW version: 24, Local IP Address: 192.168.5.39, MAC Address: b827abefafca. Includes 'Site Name' (Staging (a86a-KVM 3)), 'Enter your email address to register' (murray@atbled.com), and 'Set up dataplicity' (Dataplicity already installed).

Query DALI Power Status: Channel: 1, Address Type: Broadcast, Group: 0. A grid of 63 buttons (0-62) for selecting devices.

Manual level Control: Buttons for Off, Up, Down, Min, Max, On and Step Up, Step Down and Off, Go to scene: 0, Manual level: 100%, 75%, 50%, 25%, 0%, Color temperature (CCT): 0, Send, Query Status, Rescan Device, Reset Device.

DALI Devices Configuration (LDD): Config: Edit name: LDD, Hue name: [empty], Hide from Hue: [checked]. Groups: 0-15. Fade Time: 0 seconds, Fade Rate: 357.8 steps/second. Min Level: 145, Max Level: 254, Power On Level: 149, Fall Level: 149. Status: Channel: 1, Short address: 25, Model ID: [empty], UPC: 0, Serial #: 0, FW Version: 187, HW Version: 5, Phy Min Level: 145.

Schedule Management: Export, Browse..., No file selected, Import, New Entry, DR2F Warm (Trigger Now), Edit name: DR2F Warm, When? Sunset, Offset: 60 minutes before, On weekdays: M Tu W Th F Sa Su, Actions: Set light color temperature, Set All lights to [empty] to [empty] (2489), DR2F cool (Trigger Now), 90 minutes after sunrise: set color of all lights to 4994K, New Entry (Trigger Now), At sunrise: set all lights to level 0.

Powerful Diagnostic Tools

The DALI bus when properly installed – is a very robust and solid connection method. When incorrectly installed – it causes many problems. We provide Python scripts to manage the power, and we support this in ZWD. The AL-DALI-HAT has built in self testing of it's own master interface, the client hardware interfaces, and the interconnection wire.

The self testing occurs on these levels:

1. The presence and current delivery of all DALI bus power supplies is measured and reported. Automatic DALI power configuration means that the DALI bus will be powered and not overpowered automatically. A system engineer can override the automatic setting – but generally it can be ignored.

at power on, after 6 seconds – the HAT will measure the current supplied by all DALI power supplies, and will automatically set it's internal supply to either

- i. 0 mA – disabled
- ii. 80 mA – enabled with low current
- iii. 220 mA – enabled with high current

The onboard slide switch selects either low 80 mA or high 220 mA current sourcing. The above combinations will be attempted to deliver that goal. The onboard switch can be disabled. The current setting can be stored in EEPROM onboard. In most cases – no external DALI power supply is needed.

2. Main Power Supply Report. The HAT will report the voltages of 2 supplies, the application in the Pi can manage the lighting if one supply fails.
3. DALI Power Report. The HAT will report the voltage on the bus – it should be 12 volts or higher.

```
DALI POWER REPORT
user can set Onboard Supply to 0= Off, 1= 80 mA, 3= 180 mA, 4= auto, 5= lock

Dali Power:  Onboard Supply is Off and locked
DALI Bus= 15709 mV, 84 mA at 0 Volts, 168 mA at 12 Volts, 168 mA at 6 Volts
Supply Power      Input A 47.5 V, Input B 47.7 V, Switch Off
input command (0,1,3,4,5,q) : 4
```

```
Scan DALI bus 1
DALI BUS: power is good
```

```
address 2 is Model 01 Type 06 level 0 logic 0 = 2022mV
address 16 is Model 01 Type 06 level 0 logic 0 = 1999mV
address 17 is Model 01 Type 06 level 0 logic 0 = 1987mV
address 18 is Model 01 Type 06 level 0 logic 0 = 2034mV
address 19 is Model 01 Type 06 level 0 logic 0 = 1970mV
address 20 is Model 01 Type 06 level 0 logic 0 = 2016mV
address 21 is Model 01 Type 06 level 0 logic 0 = 1981mV
address 22 is Model 01 Type 06 level 0 logic 0 = 1981mV
address 23 is Model 01 Type 06 level 0 logic 0 = 1987mV
address 24 is Model 01 Type 06 level 0 logic 0 = 1987mV
address 25 is Model 01 Type 06 level 0 logic 0 = 2040mV
address 26 is Model 01 Type 06 level 1 logic 0 = 1999mV
address 27 is Model 01 Type 06 level 0 logic 0 = 1999mV
address 28 is Model 01 Type 06 level 0 logic 0 = 2040mV
address 29 is Model 01 Type 06 level 0 logic 0 = 1999mV
address 30 is Model 01 Type 06 level 0 logic 0 = 2005mV
address 31 is Model 01 Type 06 level 0 logic 0 = 1999mV
```

```
Start a scan  A = 47.9 Volts  B = 48.0 Volts      Switch is OFF
```

DALI bus products from ATX LED Consultants

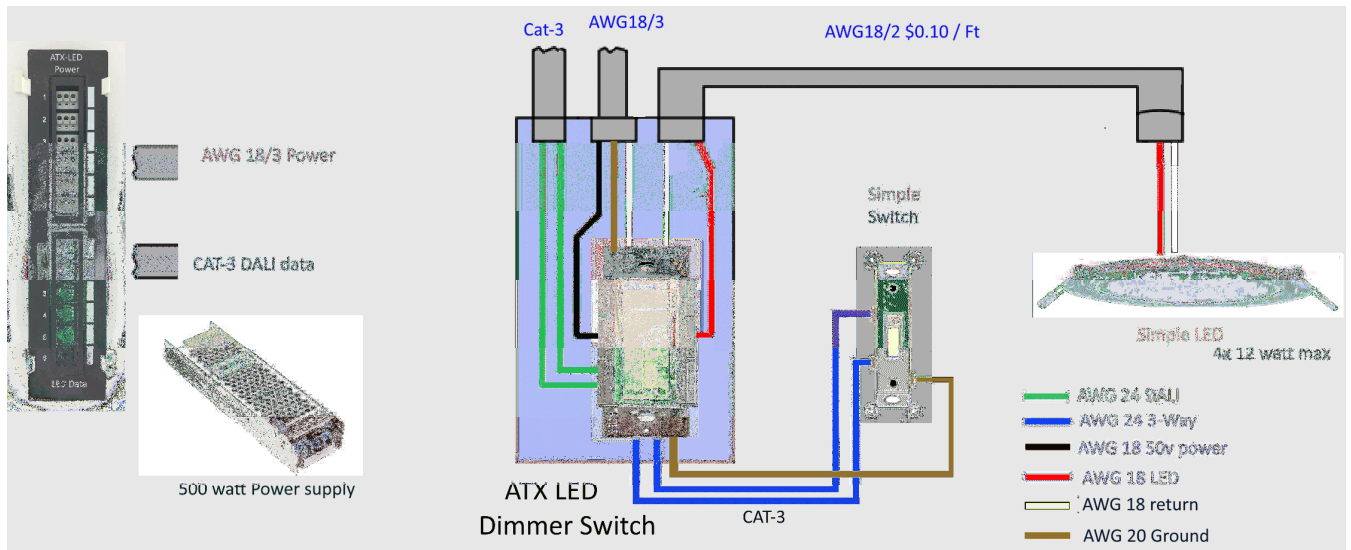

Low Voltage house lighting product line

